

HELI
LIFTING THE FUTURE



TOP1 FORKLIFT MANUFACTURING AND SALE
IN CHINA CONTINUOUSLY FOR 21 YEARS

Rear-
wheel driven

1.5 Ton
AC ELECTRIC
FORKLIFT



CHINESE EXPORT BRAND

Recommended
By China Chamber of Commerce for Import and Export of Machinery
And Electric Products



AC ELECTRIC FORKLIFT **1.5 ton**

Characteristics			
1.01	Manufacture's Name		HELI
1.02	Model Designation		CPD15S
1.03	Configuration Number		HA2H/HA3H
1.04	Load Capacity	Q(kg)	1500
1.05	Load Center	c(mm)	500
1.06	Power Type		Battery
1.07	Operator Type		Seated
1.08	Wheelbase	y(mm)	1200
Wheels & Tyres			
2.01	Tyre Type		Superelastic
2.02	Number of Wheels (x=driven) ,front/rear		2/1x
2.03	Tread(centre of tyre),front	b10 (mm)	840
2.04	Tread(centre of tyre),rear	b11 (mm)	-
2.05	Tyre Size, Front		18 x 7-8
2.06	Tyre Size, Rear		18 x 7-8
Dimensions			
3.01	Load Distance	X(mm)	330
3.02	Mast Tilt Angle,F/R	α / β (°)	3/6
3.03	Height with Mast Lowered	h1(mm)	1955
3.04	Free Lift	h2(mm)	110
3.05	Standard Lift Height	h3(mm)	3000
3.06	Height with Mast Extended	h4(mm)	4008
3.07	Overhead Guard Height	h6(mm)	2080
3.08	Fork Size T x W x L	s/e/l(mm)	35 x 100 x 920
3.09	Fork Carriage to DIN 15173 A/B		2A
3.10	Length to fork face	12(mm)	1797
3.11	Overall Width	11(mm)	990
3.12	Outside Turning Radius	Wa(mm)	1467
3.13	Ground Clearance at mast ,Loaded	m1(mm)	90
3.14	Ground Clearance at centre of wheelbase ,Loaded	m2 (mm)	100
3.15	Right Stack Aisle width (Pallet size 1000x1000mm, clearance:200mm)	Ast(mm)	3088
3.16	Right Stack Aisle width (Pallet size 1200x1200mm, clearance:200mm)	Ast(mm)	3311
Performances			
4.01	Travel Speed ,with/without load	km/h	12/12.5
4.02	Lifting Speed ,with/without load	m/s	0.28/0.48
4.03	Lowering Speed ,with/without load	m/s	0.55/0.45
4.04	Gradient performance with load/without load	%	8/15
4.05	Max. draw bar pull with load	N	7030
Weight			
5.01	Total Approximate Weight(W/O battery)	kg	2897/2237
5.02	Axle Loading: Unloaded,Front/Rear	kg	1252/1645
5.03	Axle Loading: Loaded,Front/Rear	kg	3790/607
Battery			
6.01	Battery Voltage/rated capacity(5h)	V/Ah	24/720
6.02	battery weight (min/max)	kg	660 (650/750)
6.03	Battery to DIN 43531/35/36/A/B/C		43535A
Motor & Controller			
7.01	Drive Motor - 60 Min. Rating	kW	4.2
7.02	Pump Motor - 15 Min. Rating	kW	6.2
7.03	Drive Motor Control Method		MOSFET/AC
7.04	Pump Motor Control Method		MOSFET/AC
7.05	Service Brake/Parking Brake		Hydraulic/Mechanical
7.06	Relief Pressure	Mpa	17.5

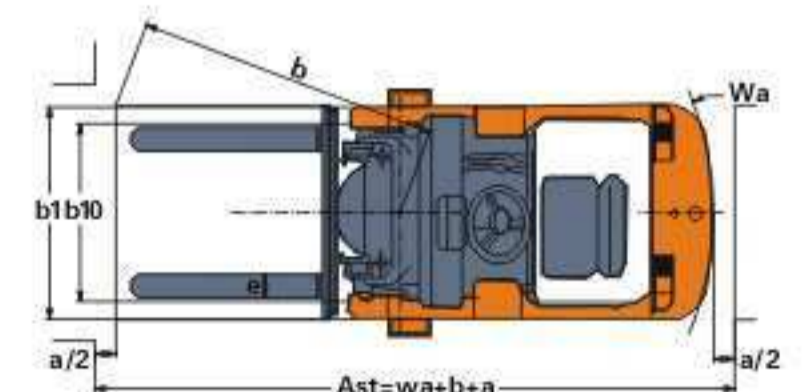
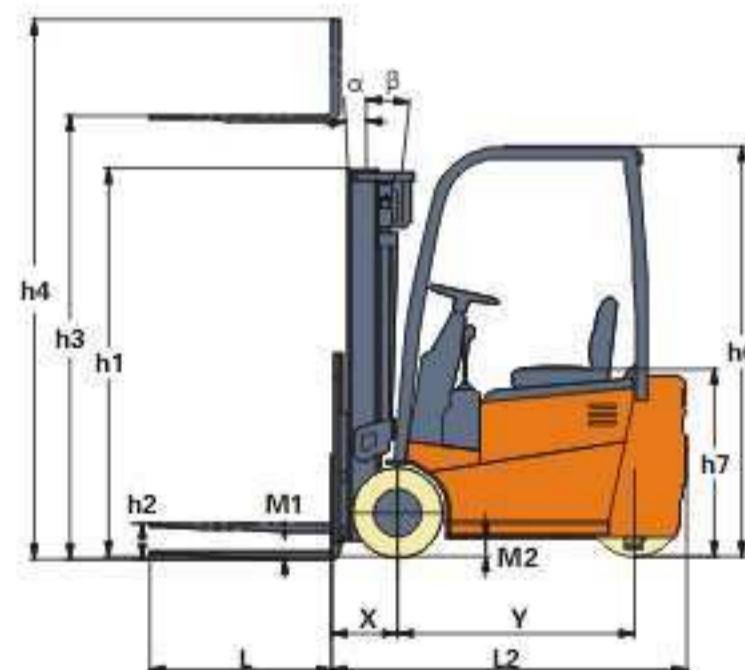
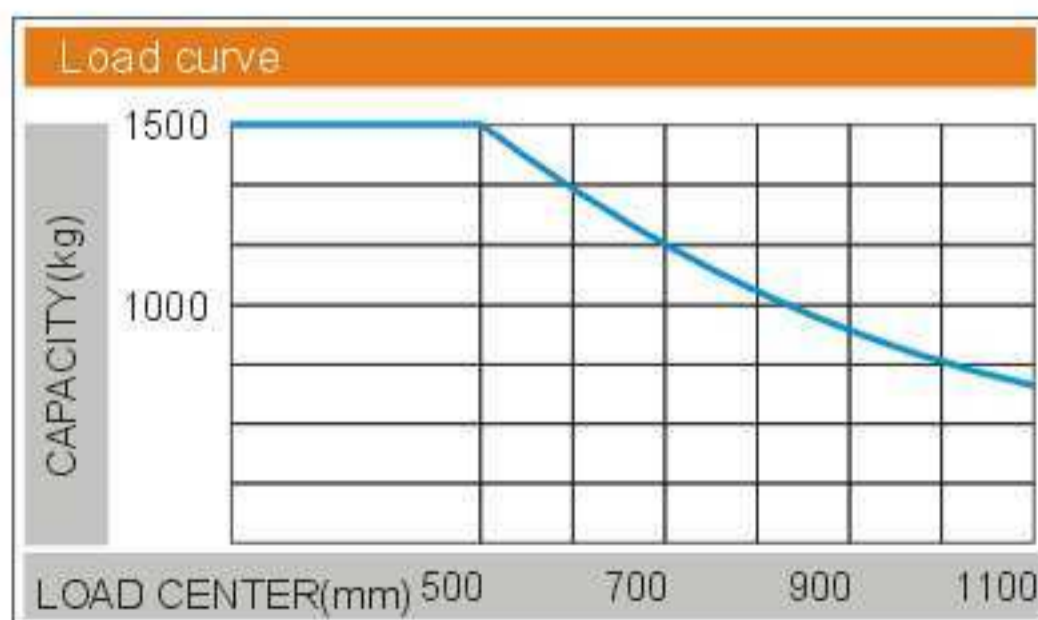

ANHUI HELI CO., LTD.
 ADDR 15 WEST WANGJIANG ROAD, HEFEL, ANHUI, P.R. CHINA
 TEL (86 551)63639068, 63639258, 63639358
 FAX (86 551)63639966
 WEBSITE <http://www.helichina.com>

AUTHORIZED DEALER

* Details of specifications and equipment are based on information available at the time of printing and may change without notice.

© 2013 heli copyright

Catalog No.2013.1 HELI Print